

# ZDClink<sup>®</sup>

*Controller with Luxor<sup>®</sup> Technology*

OWNER'S MANUAL

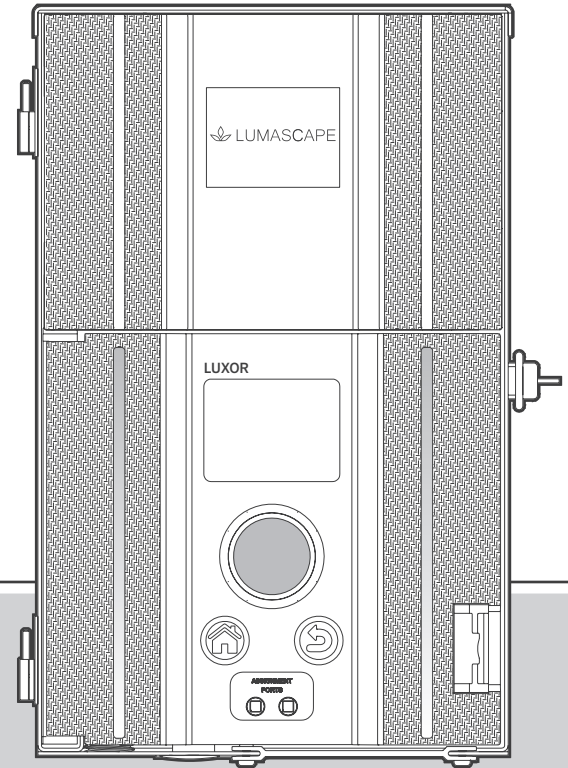

## **LED Landscape Lighting Controller**

Owner's Manual and Installation Instructions  
for the ZDClink Controller



# LUMASCAPE

---

# Table of Contents

---

<b>3</b>	<b>ZDCLink Controller Overview</b>	<b>13</b>	Time/Date	<b>26</b>	<b>Controller Linking Setup</b>
<b>3</b>	ZDCLink Controller Components	<b>14</b>	Language	<b>26</b>	Updating to Linking
<b>4</b>	Glossary of Terms	<b>14</b>	Location	<b>27</b>	Wired Connection for Satellite Controllers
<b>4</b>	Safety Information	<b>15</b>	Assign	<b>28</b>	Chassis Communication and Assignment
<b>5</b>	<b>Installing the ZDCLink Controller</b>	<b>15</b>	Network	<b>28</b>	Wireless Communication and Assignment
<b>5</b>	Locating the Transformer	<b>16</b>	Backup	<b>29</b>	<b>Care and Maintenance</b>
<b>5</b>	Mounting the Transformer	<b>16</b>	How to Restore an Existing File	<b>29</b>	Regular Preventive Maintenance
<b>8</b>	Running Cable to the Luminaires	<b>17</b>	Assigning Luminaires into Groups	<b>30</b>	Troubleshooting
<b>10</b>	Low-Voltage Cable	<b>18</b>	Setting Up Programs	<b>31</b>	Firmware Updates
<b>10</b>	Cabling Methods	<b>19</b>	Calendar-Based Programming	<b>33</b>	Fuse Replacement
<b>10</b>	Connecting Cables at the Terminal Block	<b>19</b>	Themes	<b>34</b>	System Reset
<b>11</b>	<b>Operating the ZDCLink Controller</b>	<b>20</b>	Manual Mode	<b>34</b>	Facepack Reset
<b>11</b>	Navigating the ZDCLink Controller	<b>21</b>	Color	<b>35</b>	Database Reset
<b>11</b>	Home Screen	<b>21</b>	Color Palette	<b>35</b>	Chassis Indicator Lights
<b>12</b>	Activity Screen	<b>22</b>	Color Wheel	<b>36</b>	<b>Warranty</b>
<b>12</b>	Diagnostics Screen	<b>23</b>	Mixing Z, ZD Technology®, and ZDC Technology®	<b>38</b>	<b>Notes</b>
<b>13</b>	Setup Screen	<b>24</b>	Using Other Devices with the ZDCLink Controller	<b>41</b>	<b>Luminaire Group Stickers</b>
		<b>25</b>	Disable		

\*Use the stickers attached to the back of this guide to simplify group assignments when programming luminaires at the ZDCLink Controller facepack or with the Light Assignment Module.

The ZDClk Controller is a lighting transformer capable of controlling groups of lights that are initiated by programmed events. These events are adjustments of light intensity at set times. All lights within a system are communicated with and powered via two-wire connections. All lights within a system communicate with the same two-wire connections that also power the system.



**Note**

The ZDClk Controller is intended for use with Lumascape low-voltage LED luminaires or devices containing ZD Technology or ZDC Technology. Use of other luminaires is not recommended due to the absence of communication capabilities. It is not for use with incandescent luminaires.

## ZDClk Controller Components

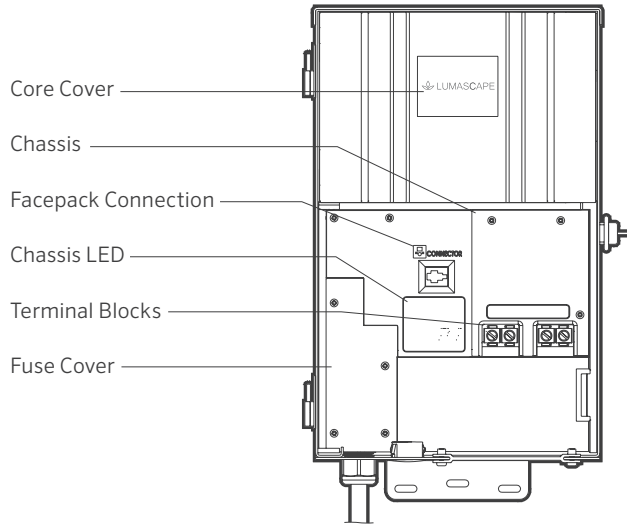

Figure 1: ZDClk Controller

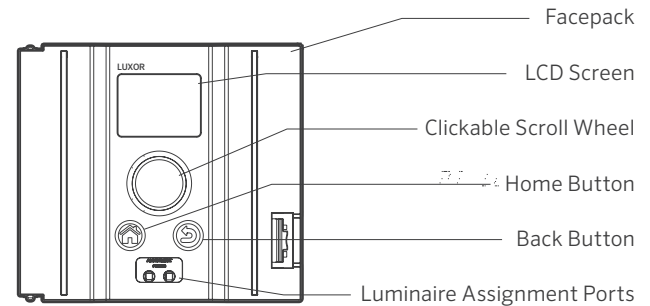

Figure 2: ZDClk Facepack

## Glossary of Terms

**Group:** An addressed set of lights that is designated numerically and controlled as a set by the controller

**Theme:** A predetermined set of groups, intensities, and colors called to action by the program or manual functions

**Luminaire:** Light unit that contains an zoning, dimming, or color capabilities

**Intensity:** Value indicating the measurable amount of brightness, from 1% to 100%

**Event:** The initiation, adjustment, or conclusion of a selected theme or group with specific intensity and/or color settings

**Duration:** The length of time an event will run

**Hue:** The primary attribute of a color; it is represented by a numeric value between 0 and 359

**Saturation:** The richness of a color mixed with white light, from 0% to 100%

**Color:** The visual combination of hue and saturation

**Primary Controller:** ZDCLink Controller containing a facepack

**Satellite Controller:** Controller without a facepack

## Safety Information

These cord-connected units consist of step-down, isolated, two-winding-type transformers, circuit breakers, and associated circuitry intended to supply power to low-voltage, submersible luminaires.

**WARNING — Risk of Electric Shock.** Install the power unit 5' (1.5 m) or more from a pool or spa and 10' (3 m) or more from a fountain. Where the power unit is installed within 10' (3 m) of a pool or spa, connect power unit to a GFCI-protected branch circuit. Do not use an extension cord when connecting the power unit to the 120 V source. The grounding conductor shall be 12 AWG (2.05 mm) minimum. The outdoor power unit shall be connected to a GFCI-protected, hooded, flush-type cover plate receptacle marked “Wet Location” while in use.

**Caution:** The supply circuit for the landscape lighting system shall be protected by a Class A-type ground fault circuit interrupter, unless it is provided with the landscape lighting system. This device is accepted as a component of a landscape lighting system where the suitability of the combination shall be determined by local inspection authorities having jurisdiction. Do not connect two or more power supplies in parallel. Not for use in dwelling units. This presents a risk of fire. Do not place insulation under the terminal plate. Check the connector after installation.

## Circuit Protection

- 12.5 A for a 150 W controller
- 22 A for a 300 W controller

## Locating the Transformer

1. Locate the transformer in a well-ventilated area away from direct irrigation spray and central to the proposed installation site of the majority of the luminaires. The primary goal is to minimize the length of cable runs from the transformer to the luminaires, which minimizes voltage drop and cable size. A common mistake is to locate the single transformer on the service side of the house or in the garage, which might result in excessively long cable runs to reach lighted areas. Transformers with power cords must be located adjacent to a 120 V, GFCI-protected exterior electrical receptacle. If a 120 V power source is not available at the desired transformer installation location, hire a licensed electrician to run a dedicated 120 V, 15 A circuit to the desired location. For international ZDClick Controller models, the previously mentioned information applies for 230 V, 10 A circuits.
2. Test all existing receptacles with both a receptacle tester and a digital voltmeter or amp clamp to verify proper wiring and voltage at the receptacle.

## Mounting the Transformer

### Wall-Mount Installation

1. Install all transformers a minimum of 12" (30.5 cm) above the finish grade, as measured from finish grade to the bottom of the transformer and according to code.
2. Drill pilot holes into the mounting surface, insert anchors, and install screws into the anchors, leaving approximately 1/8" (3 mm) of the thread exposed on the screw. Mount the transformer on the screw.

3. Use a level and a pencil to determine and mark locations for the bottom anchors. Remove the transformer from the wall. Drill the anchor holes and install the anchors.
4. Place the transformer back on top of the uppermost mounting screw. Then install the screws into the anchors at the bottom of the transformer to secure it to the wall.

### Post-Mount Installation

1. Install a pressure-treated 4" x 4" x 36" (10 cm x 10 cm x 92 cm) or larger post in concrete footing.
2. Repeat the wall-mount installation instructions (Figure 3 on page 6) without using wall anchors.

All ZDClick Controllers come equipped with a 5' (1.5 m), 12 AWG (2.05 mm), three-prong electrical power cord. Only use the ZDClick power cord in conjunction with a GFCI-protected, 120 V exterior receptacle (or 230 V receptacle for international/export version).



### Note

When installing the Wi-Fi Module, consider increasing the installation height to improve signal strength and screen visibility.

# Installing the ZDCLink Controller

Figure 3: Wall mounting

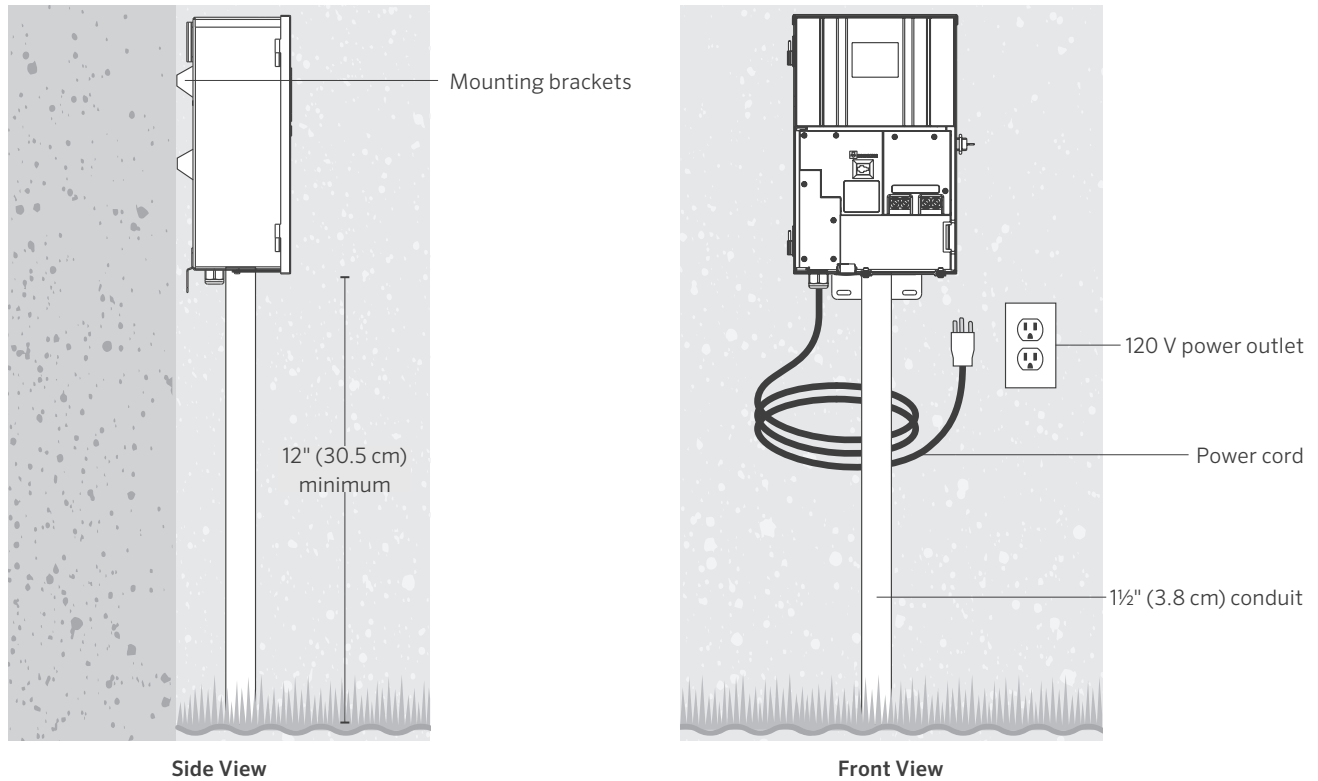
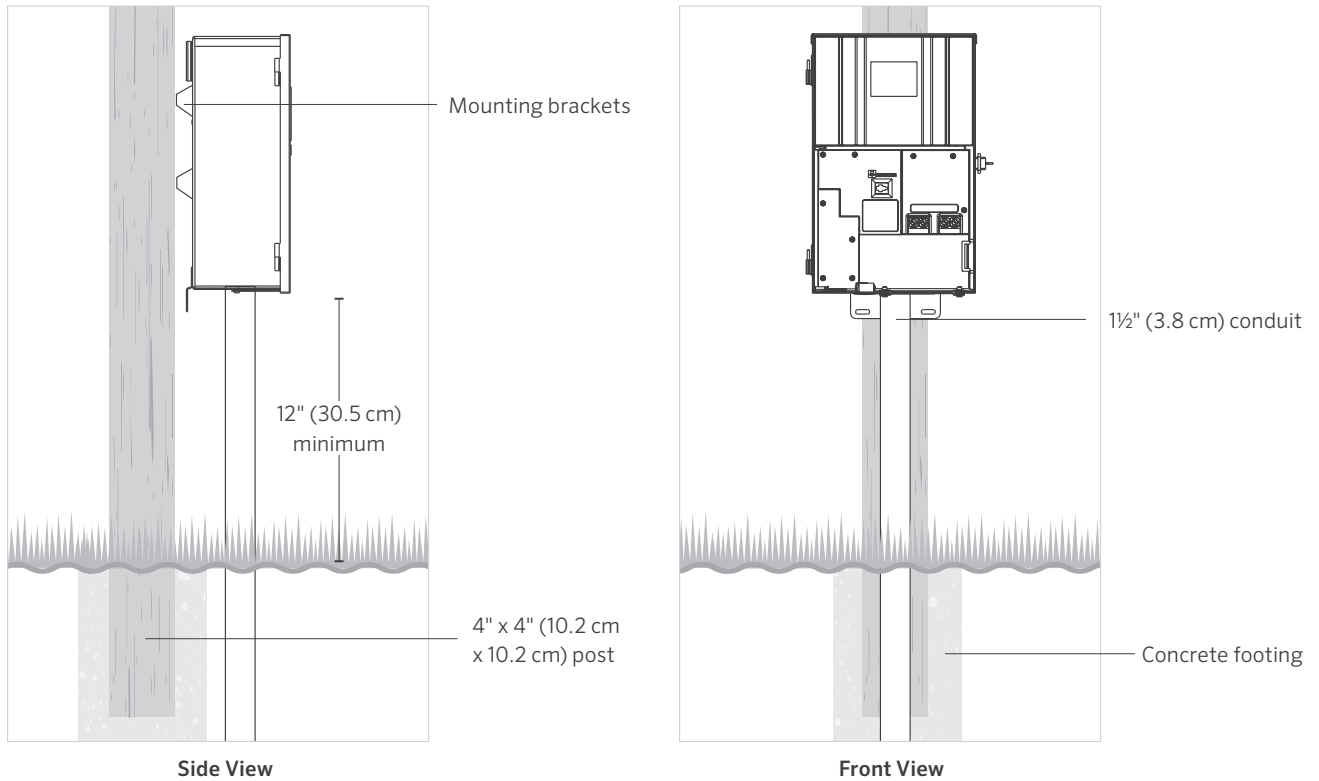

Figure 4: Post mounting



# Installing the ZDClick Controller

## Running Cable to the Luminaires

After you install the transformer and determine all luminaire locations, run a correctly sized cable from the transformer to the luminaires. Lumescape low-voltage LED luminaires require between 10 and 15 V for optimal operation and longevity. This is accomplished by the following:

1. Group luminaires into distance zones as illustrated below. Do not include a luminaire that is 10' (3 m) away from the transformer on the same cable run as one that is 100' (30 m) away.
2. Use the proper cabling method for the application. Center-load all cable runs to minimize the voltage differential between luminaires.
3. Use a correctly sized cable to accommodate voltage drop. As a general best practice, limit the wattage load per cable run to no more than 160 W.

## CIRCUITING GUIDELINES

### Loads Per Cable



#### Close Zone: 0 to 40' (0 to 12.2 m)

12 AWG (2.05 mm): 160 W max.

10 AWG (2.59 mm): 180 W max.

8 AWG (3.26 mm): 220 W max.

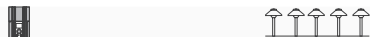

#### Mid Zone: 40 to 80' (12.2 to 24.4 m)

12 AWG (2.05 mm): 120 W max.

10 AWG (2.59 mm): 140 W max.

8 AWG (3.26 mm): 200 W max.

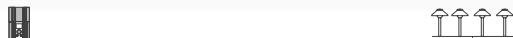

#### Far Zone: 80 to 120' (24.4 to 36.6 m)

12 AWG (2.05 mm): 100 W max.

10 AWG (2.59 mm): 120 W max.

8 AWG (3.26 mm): 180 W max.

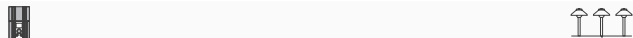

#### Out There Zone: 120 to 160' (36.6 to 54.9 m)

12 AWG (2.05 mm): 60 W max.

10 AWG (2.59 mm): 100 W max.

8 AWG (3.26 mm): 160 W max.



## Summary

For maximum light output and LED life, each luminaire should be provided with 10 to 15 VAC (ZD) and 11 to 15 VAC (ZDC).

## Cable Stats

Low-voltage lighting systems are typically installed using stranded, direct-burial-rated cable. The most common cable used is 12/2 AWG (2.05 mm) stranded cable. The size of cable used in wiring the lighting system will be determined by the wattage load and length of cable run from the transformer to the luminaires.

It is very important to note that all low-voltage cable has a maximum rating. Overloading cable can create a dangerous safety hazard, so be sure to choose the right cable size for your lighting system.

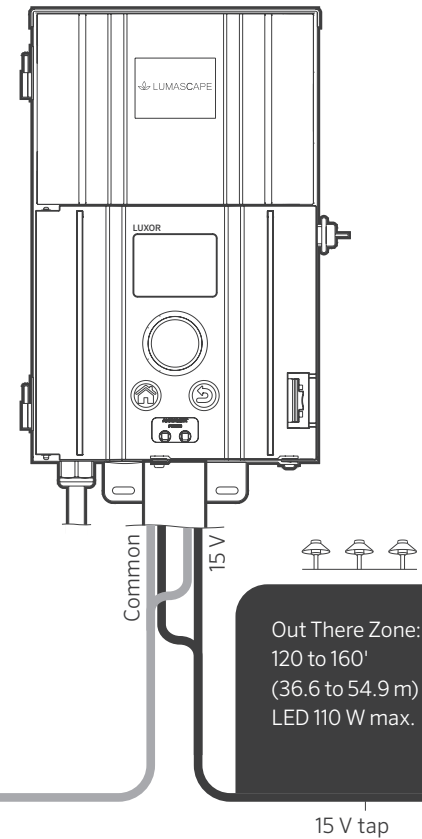

Watts shown are per 12 AWG (2.05 mm) cable. Install additional cable runs as needed to complete the project. To increase the maximum wattage, run 8 AWG (3.26 mm) or double 12 AWG (2.05 mm) to the first luminaire in the zone. Use a digital voltmeter to fine-tune circuits.

Figure 5: Wiring example

# Installing the ZDClk Controller

## Low-Voltage Cable

Each low-voltage lighting cable consists of two parts. The part of the cable that carries the voltage load is referred to as the Common lead. The Common lead is installed into one of the two COM terminal blocks. The other wire lead is installed into one of the two lugs labeled 15 V. Voltage is carried out from the transformer to the luminaires via the Common side of the cable and returns back to the transformer 15 V tap via the other half of the cable to complete the circuit.

## Cabling Methods

Within each cabling zone, you may utilize several cabling methods. The primary objective is to minimize voltage drop by installing a properly sized feeder cable (home run) to each zone, and to make sure all luminaires with ZD Technology on each cable run are receiving 10 to 15 V (or 11 to 15 V for luminaires with ZDC Technology).

## Connecting Cables at the Terminal Block

Transformer terminal block: The ZDClk Controller includes two Common lugs and two 15 V lugs.

**Common Lugs:** One conductor from each cable run coming from the lights to the transformer must be connected to one of the common lugs. The other conductor will be installed into the 15 V hot lug.

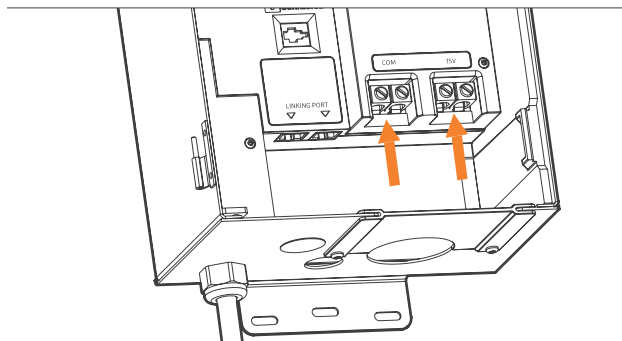

Figure 6: Output terminal blocks

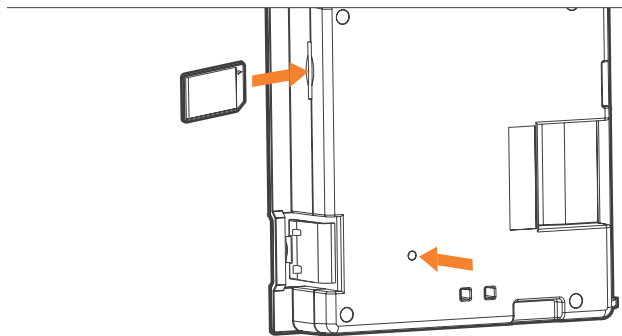

Figure 7: Back of facepack showing SD card and reset button

## Navigating the ZDClint Controller

The ZDClint Controller contains only three user interface elements:

- **Home** button: Opens main screen while on any other function
- **Help** button: Navigates to previous screen
- Clickable scroll wheel: Primary interaction and selection tool

### Home Screen

All functions on the controller are accessible through the **Home** screen. The default display on the **Home** screen displays the following:

- Current time
- Current date
- Sunrise/sunset for the current day (dependent on location; see **Set Location**)
- All category options



Figure 8: Home screenshot

All category options are located on the right side of the **Home** screen and are selected using the main scroll wheel. Turn the scroll wheel clockwise or counterclockwise until the desired category is highlighted in light blue. Press the scroll wheel inward to select and enter the desired category.

- While in any screen, press the **Home** button to return to the **Home** screen.
- While in any screen, the **Back** button can be pressed to return to the previous screen.

## Activity Screen

After five minutes of inactivity, an **Activity** screen will appear on the LCD screen if the lights are running. The wait time is reduced to only five seconds when the current screen is the **Home** screen.

The **Activity** screen displays:

- Chassis load: Amp load of controller chassis. Chassis 1-10 are displayed. Only chassis with an active load will display an orange load bar.
- Current time
- Source of transformer load: Manual or Schedule

You cannot make selections on this screen; it is simply an activity display. Press the **Home** button to return to the **Home** screen.

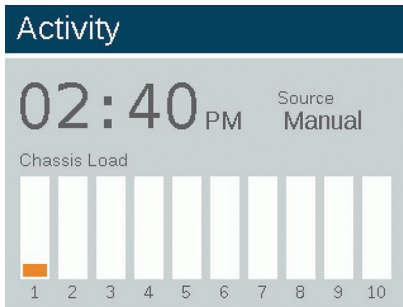

Figure 9: Activity screenshot

## Diagnostics Screen

Assigned: Controller assigned

Communicating: Controller communicating

Overload: Controller overload indication

Load Status: Controller load as a percentage

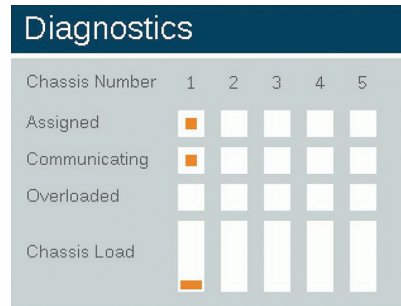

Figure 10: Diagnostics screenshot

## Setup Screen

All background tools and settings (except color) are accessible in the **Setup** screen. Scroll through the various options to set up the controller.

### Time/Date

- Set the three time categories (Hr:Min:Sec) to the current time settings by pushing the scroll wheel when the appropriate field is highlighted, scrolling through the numeric options, and pressing the scroll wheel again to finalize the selection.
- Turn past 12 on the hour (“Hr”) setting to adjust a.m. and p.m., as displayed next to the seconds (“Sec”).
- To convert clock to 24-hour convention, select the “24hr” selection box.
- Set the three date categories (Month, Day, Year) to the current date by pushing the scroll wheel when the appropriate field is highlighted, scrolling through the options, and pressing the scroll wheel again to finalize the selection.
- Setting the month, day, and year automatically sets the day of the week, which appears to the right of the year.
- When activated, Daylight Saving Time (DST), will adjust the time forward or backward by one hour at the appropriate dates each year. To initiate it, select **On**. To deactivate it, select **Off**.
- Select **Auto** to sync the controller time clock every 24 hours.

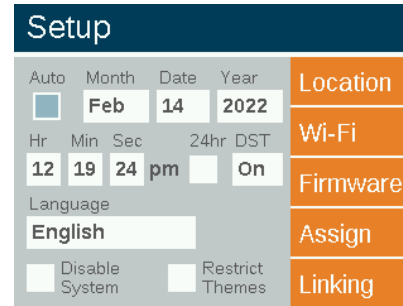

Figure 11: Setup screenshot

## Language

In the **Setup** screen, select the language field by pressing the scroll wheel and turning it to the desired language. Press the scroll wheel again to finalize the selection.

- The language change will not take effect until either the **Back** or the **Home** buttons are pressed.

## Location

The **Location** menu is designed to graphically represent a controller's location on a map for accurate sunrise and sunset times based on the current date, time zone, and longitude/latitude settings.

First, select **Location** from the **Setup** screen. While in the Location screen, select **Region**. Once region is selected, scroll to **Time Zone** and select the current time zone.

If latitude and longitude coordinates are known, enter the values in the **Lat** and **Long** fields. To set latitude and longitude using the map feature, scroll to **Map** and press the scroll wheel.

- The full-screen crosshairs designate the user's location on the map. The map will change based on the selected region.
- Latitude is first adjusted by rotating the scroll wheel to move the crosshairs up and down. Numeric indicators at the top right area of the screen will display the actual coordinate. Press the scroll wheel to select the latitude; it is set by pressing the click wheel.
- Next, adjust the longitude by rotating the scroll wheel to move the crosshairs left and right.

- The coordinate settings are automatically saved after each press of the scroll wheel. Select the **Home** button to leave the **Location** screen.
- To initiate a reset or adjustment, press the scroll wheel and repeat the steps listed for setting latitude and longitude.



Figure 12: Location Screen

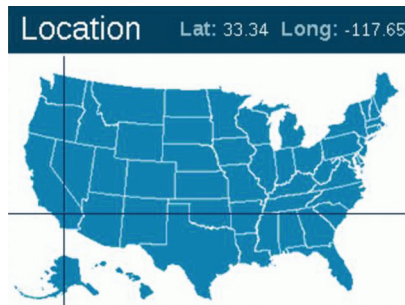

Figure 13: Location map of the United States

## Assign

When compatible luminaires are plugged into the luminaire programming ports, the assign screen will automatically display. The **Assign** screen is also accessible under the **Setup** menu.

## Network

By default, the LAN tab will be displayed. The Wi-Fi or label will be displayed when the Wi-Fi Module is inserted into the accessory port in the back of the facepack. For more information on using the Wi-Fi, refer to the separate owner's manual for ZDClk Accessories.

## Restrict

The restrict function prevents changes to themes.

1. From the **Home** screen, navigate to the **Setup** and select **Restrict Themes** screens using the scroll wheel.
2. To remove the restriction, deselect **Restrict Themes**.

## Backup

The backup function saves all information entered into the controller, including programs, themes, colors, and setup data. To create a backup file for your ZDClint Controller, follow the steps below.

1. Insert an SD card into the side of the facepack with the pins facing toward the front of the facepack.
2. From the **Home** screen, navigate to the **Setup** and then **Firmware** screens using the scroll wheel.
3. Navigate to **Backup** using the scroll wheel.
4. Input a file name for the backup file. You do not need to use all available spaces.
5. Press **Backup**.
6. After backup is successful, press the SD card inward and then release to remove the card from the facepack.

## How to Restore an Existing File

1. Insert an SD card (pins facing the front) with the preloaded file into the side of the facepack. Press the card completely inward and then release. The card will lock into place.
2. From the **Home** screen, navigate to the **Setup** and then **Firmware** screens using the scroll wheel.
3. Navigate to **Backup** using the scroll wheel.
4. Input the file name of the desired database to restore. The filename must match exactly.
5. Press **Restore**.
6. After a successful restore, press the SD card inward and then release to remove the card from the facepack.



## Assigning Luminaires into Groups

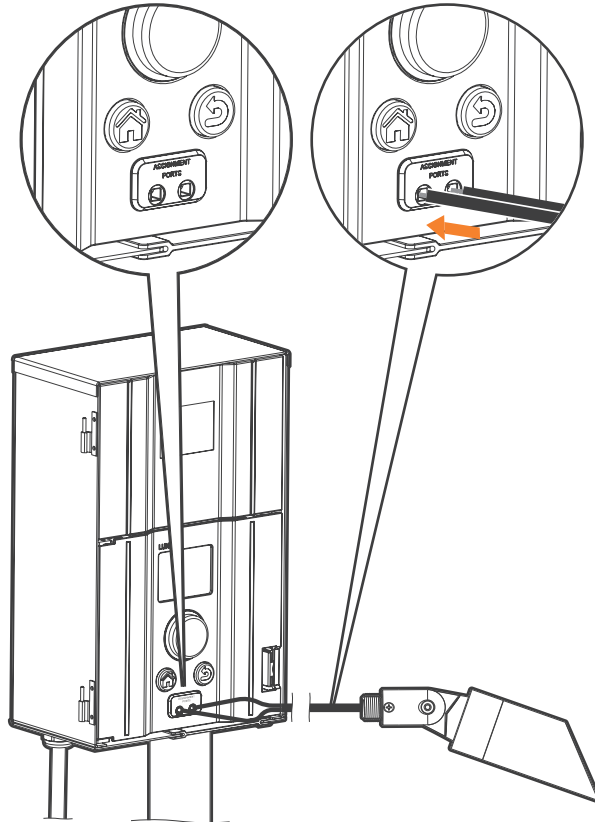

Figure 14: Luminaire assignment wire diagram

The lighting assignment screen is automatically displayed when a Lumascape low-voltage LED luminaire or device containing ZD Technology or ZDC Technology is connected into the assignment ports of the controller facepack. This mode can also be forced by navigating to **Setup** and selecting **Assign**.

1. Enter this mode by placing two separate wires from a single Lumascape low-voltage LED luminaire or device containing ZD Technology or ZDC Technology into each of the assignment ports on the front of the facepack. The wires must maintain contact inside the assignment ports during the entire process.
2. Navigate to **Program** and press the scroll wheel to initiate assignment. When complete, the screen will show “Assignment Successful” or “Assignment Failed.” If failed, reposition wires and try again. If the problem persists, the board or device may either be defective or not programmable.
3. The assigned group number is stored in the device (e.g., LED board, lamp, CUBE) and not in the facepack. Thus, power loss or other errors within the ZDClk Controller will not affect the luminaire assignment. If a device is replaced, the new device must be programmed to the desired group number.



### Note

Always address one luminaire at a time. Attempting to address more than one luminaire at a time can result in assignment failures.

## Setting Up Programs

The **Programs** screen is where all daily running programs are set up. Programs are set by scheduling luminaires that have been assigned to groups or themes. For more about assigning luminaires to groups, see “Assigning Luminaires into Groups” on page 17.

1. Each program is designated by a letter (“A” through “G”) at the top right section of the screen. Select the desired letter using the scroll wheel prior to selecting the days of the week.
2. Selecting days of the week designates which days the program will run based on the event settings. Select or remove each day by highlighting the corresponding box over each day with the scroll wheel and pushing to select or deselect.
3. The **Event** field specifies the factors that will initiate a timed event. Options include sunrise, sunset, or time.
4. The **Time** field specifies what time the programmed event will occur. Sunrise/sunset times are based off of astronomical timing set by the location (longitude and latitude) of the unit. Optional timed offsets ( $\pm$  15-minute increments) are available for sunrise/sunset events. Time events are determined by the time of day.
5. The **Group/Theme** field specifies which group or theme is associated with each event. Scroll right to select groups. Scroll left to select available themes.
6. The **Color** field specifies the desired color for group events. Colors are not available for themes.

The **%** field specifies the desired intensity for each event. Values range from 0% (off) to 100%. Theme events are limited to On or Off.

You can create multiple events to initiate or change luminaire intensities, but you must use a separate event to turn them off.



Figure 15: Programs screenshot



### Note on Day Beginning and End

Days are designated to start and end at noon (12 p.m.). This allows lights to continue running after midnight within a single day's program setting.

## Calendar-Based Programming

Calendar-based programming allows program(s) to run during specific dates throughout the year.

To set a calendar-based program, enter the Date-Based Scheduling screen by selecting the calendar icon located in the right-hand corner of the **Program** screen.

Users can select the **Start** and **End** dates for each desired program. Selecting **Exclusive** will allow the controller to only run the specified program during the requested dates. The controller will revert back to the non-exclusive programs after the controller is outside of the **Exclusive** date range.

Program	Start Date	End Date	Exclusive
A	Jan 1	Dec 31	<input type="checkbox"/>
B	Feb 14	Feb 15	<input checked="" type="checkbox"/>
C	Jul 1	Jul 5	<input checked="" type="checkbox"/>
D	Oct 30	Nov 1	<input checked="" type="checkbox"/>
E	Dec 1	Dec 26	<input checked="" type="checkbox"/>

Figure 16: Date-Based Scheduling screenshot



### Note

Calendar-based programs are not required for controller operation.

## Themes

A theme is a planned set of groups at stated colors and intensities. A user can call up themes in the **Program** menu for quick setting of a series of groups, or in the **Manual** menu for on-demand control. Common uses for themes include location-based (e.g., gazebo) and lifestyle-based (e.g., vacation or party).

- Themes are set initially by selecting the **Theme** function from the **Home** screen.
- Each theme is designated by a letter (“A” through “Z”) at the top right section of the screen. Select the desired letter using the scroll wheel.
- Enter the various groups selected for the theme, with corresponding colors and intensities.

# Operating the ZDClk Controller

1. Select the **Test Theme** checkbox to temporarily turn on all groups that have been set in a theme. While this function is active, a user can make adjustments to the theme and see the changes in real time. Test theme function will end when a key has not been pressed for five minutes, the home key is pressed, or another theme is selected.
2. To completely clear the theme, select the **Erase** button. This function clears all fields in the theme and removes the erased theme from any existing programs.

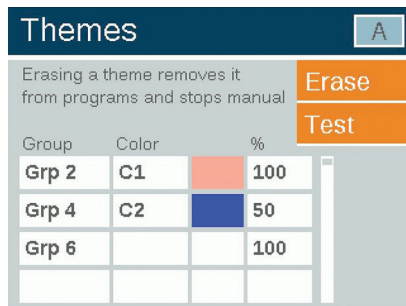

Figure 17: Themes screenshot

## Manual Mode

Use **Manual** mode to turn on and adjust lights outside of the set programs. Manual settings will always take precedence over any currently running programs.

3. From the **Home** screen, navigate to the **Manual** screen using the scroll wheel.
4. Designate a group number and then the intensity at which the given group should be illuminated.

5. Set the duration, or the amount of time that the group will run.
6. Navigate to and select the **Start** button with the scroll wheel.
7. To stop the countdown, the **Stop** button should be activated. This will only pause to allow for adjustments and should not delete any settings above.

If the group is currently running within a program, the manual setting will take precedence.

When the manual settings are finished, the regularly scheduled program will immediately continue operating at the next event time, even if it was interrupted.

After manual settings have been started, the intensity and time can be adjusted while the program is still running.

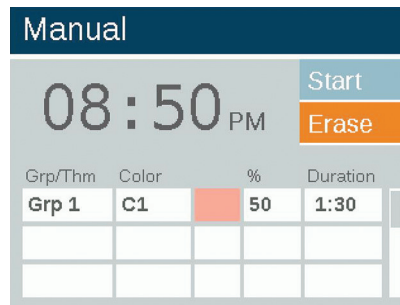

Figure 18: Manual screenshot

## Color

ZDC Technology adds color to existing zoning and dimming options. A color system requires that an LED board with ZDC Technology is installed into each desired LED luminaire. Standard and ZD Technology enabled will zone and zone/dim, respectively, but color is achieved only through the use of specific LED boards with ZDC Technology.



Figure 19: Home screen

## Color Palette

Colors are selected on the **Color Palette** screen. The ZDClk Controller can store up to 250 preset colors, labeled numerically as seen in Figure 20. Each color requires hue and saturation values. Hue is the primary attribute of a color. The selected value is found on the standard color wheel and is represented by numeric values between 0 and 359. Saturation is the percentage of hue seen with white light filling in the remainder (e.g., 80% saturation is 80% of the selected hue and 20% of white light).



Figure 20: Color palette screenshot

- Access the color palette by selecting the **Color** function from the **Home** screen.
- Only four colors are displayed at a time. Turn the scroll wheel clockwise to access the remaining 246 color labels.
- Use the scroll wheel to highlight the desired color label (e.g., C1). Adjust the hue/saturation settings using one of two methods:
  1. **Color Swatch:** Scroll one click to the right to highlight the color swatch and press the scroll wheel to open the **Color Selection** screen. Adjust the **Hue** (top) and/or **Saturation** (bottom) by selecting the appropriate chart, scrolling left or right until the desired setting is located, and pressing the scroll wheel again to finalize the setting.
  2. **Hue/Sat Values:** Scroll to highlight the hue or saturation numeric values. Press the scroll wheel to select, then scroll to select the desired values. Press the scroll wheel again to finalize the setting.

- The test group column allows the user to view the created color of a specific group. The color will remain active until the color palette screen is exited or the test group is set to off. Scroll to the test group box and select a group to activate a color label onto that group.
- Changes to colors in real time are made when the color is active through a test group, a theme, a program, or a manual program.

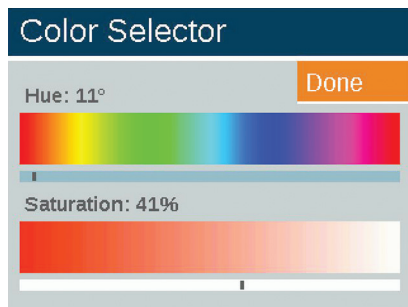

Figure 21: Color selector screenshot

## Color Wheel

The color wheel feature scans through all 300 hues constantly at intervals determined by the user. The scan is applied at the group level, allowing various groups to cycle at different colors and rates.

1. Access the color wheel menu by selecting the **Color Wheel** function from the **Home** screen.
2. Choose a label for your wheel (e.g., CW2).
3. Select a starting color. This is a user-defined color from the **Color Palette** menu.
4. Select the number of seconds in which the controller will scan through all 300 hues, beginning first at the "Starting Color." For rapid color changes, choose a lower number of seconds.
5. Apply the color wheel into programs, themes, and manual modes using the same principles described in the "Color" section (page 21). Rather than applying a single color to each group (e.g., C1), scroll the reverse direction to apply a color wheel (e.g., CW1).



### Note

Color and non-color LED boards must be assigned to different groups.

---

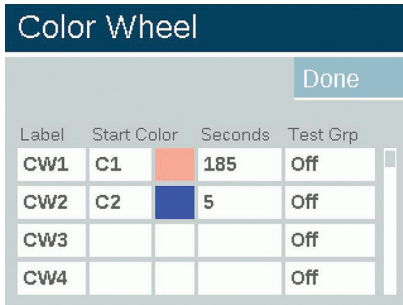

Figure 22: Color wheel screenshot

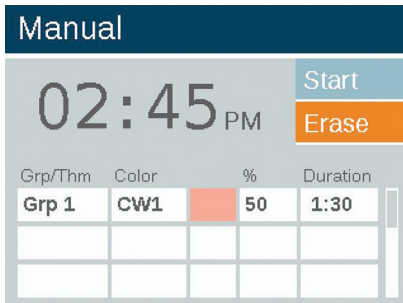

Figure 23: Manual mode screenshot

### Mixing Standard, ZD Technology®, and ZDC Technology®

Lumascaple offers a variety of LED boards with ascending functionality when used with the ZDLink Controller. The standard board is zoneable, the ZD Technology board offers zoning and dimming, and ZDC Technology encompasses the first two and adds color to the mix.

	STANDARD	ZD	ZDC
Zoning	●	●	●
Dimming		●	●
Color			●

When "all lights on" is activated in the **Manual** mode with an assigned color, non-color lights (e.g., standard and ZD) will not turn on. Select the white color (0 hue and 0 sat) to ensure all lights come on in this mode.

## Using Other Devices with the ZDClick Controller

The ZDClick Controller can communicate with devices other than Lumascape low-voltage LED boards. Two of those devices include the ZDClick CUBE and the ZDClick MR-16 ZD LED Lamp.

### ZDClick CUBE

For a total smart yard management solution, the ZDClick CUBE allows the ZDClick Controller to control, zone, and dim luminaires and other devices that don't have built-in ZD Technology. Install the CUBE in-line prior to the luminaires or devices you wish to control as a zone. When that zone is activated by the controller, all luminaires or devices in-line after the CUBE will initiate and dim according to the commands given by the controller.

The CUBE is offered in three models to ensure maximum design flexibility:

- Low-Voltage Lighting (LCM-LV)
- Line-Voltage Lighting (LCM-HV)
- Relay and 0-10 V Dimming (LCM-RLY-010V)

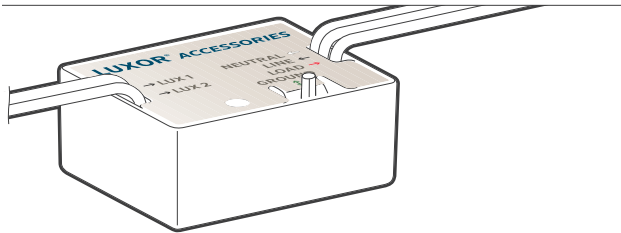

Figure 24: LCM-HV CUBE

### MR-16 ZD LED Lamp

The MR-16 ZD LED Lamp is a convenient, high-quality solution that converts incandescent luminaires to energy-efficient LED luminaires. When connected to a ZDClick Controller, the MR-16 ZD adds zoning, dimming, and control capabilities to any brand of low-voltage luminaire that has an MR-16 socket.

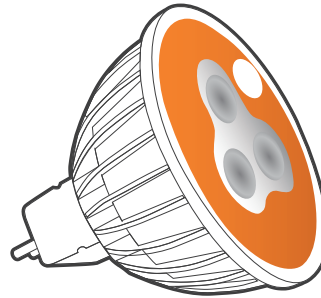

Figure 25: MR-16 ZD LED Lamp



## Disable

The **Disable** option allows you to completely shut down all lighting events in the **Manual** and **Program** modes regardless of time or status, indefinitely. This mode does not turn off the unit but rather suspends all lighting events until the user decides to reactivate. The lights will remain off after a reactivation is executed and will not turn back on until the next event (program or manual) occurs.

1. The **Disable** feature is accessed from the **Setup** screen.
2. When **Disable System** is selected, the unit will immediately shut down all luminaires in **Programs**, **Manual**, or **Themes**.
3. All lights will remain off and the lights will not reactivate until **Disable System** is deselected. If in the **Off** state and a manual event is initiated, it will run until finished or another **Disable System** is performed.
4. The **Home** screen will show “**Off**” in place of the current time when the unit is shut down.

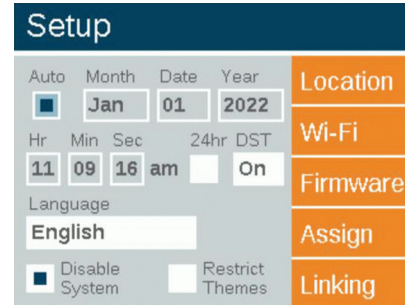

Figure 26: Shutdown screenshot



Figure 27: Home screen in disabled mode

# Controller Linking Setup

---

ZDCLink Linking allows for a single point of control for sites that require multiple ZDCLink Controllers. A linking system can contain a total of nine satellite controllers.

**Primary controller:** A ZDCLink Controller with a facepack installed. Linking firmware is required for both facepack and chassis.

**Satellite controller:** A controller with no facepack installed.



### Note

Prior to running a Linking system, verify primary and satellite controllers have the latest version of linking firmware for both the facepack and chassis.

---

Linking firmware is required for the chassis.

### Updating to Linking

1. From the product page, download the latest facepack and chassis ZDCLink Linking firmware onto an SD card.
2. Update facepack firmware.
3. Update chassis firmware.

Chassis firmware updates take about 15 minutes. The progress bar shown at the bottom of the facepack indicates the progress of the firmware update. Do not unplug power or Cat 6 connections while firmware updates are in process.



### Note

More information on updating firmware can be found under "Firmware Updates" (page 31).

---

## Wired Connection for Satellite Controllers

1. Disconnect power to the primary and satellite controllers.
2. Insert one end of Cat 6 cable into the linking port of the primary controller.

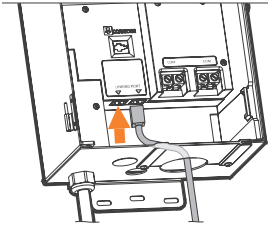

Figure 28: Primary controller

3. Insert the opposite end of the Cat 6 cable into the linking port of the desired satellite controller.

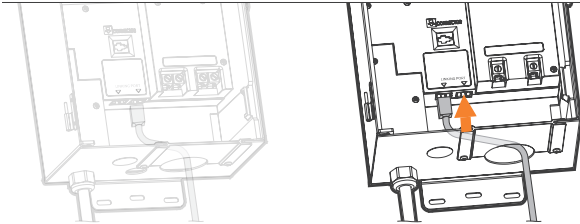

Figure 29: Satellite controller

4. If site requires multiple satellite controllers, insert new Cat 6 cable into the unused linking port of the previous satellite controller.
5. Insert the opposite end of the Cat 6 cable into the unused linking port of the next satellite controller.

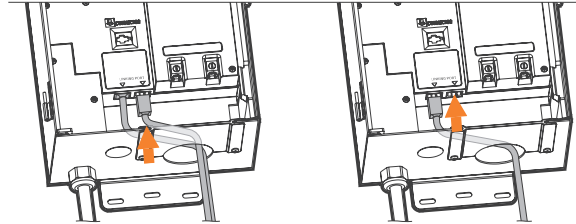

Figure 30: Satellite controller

6. Continue this connection method until all satellite units are installed in series with the primary controller.

## Chassis Communication and Assignment

1. Restore power to the primary controller.
2. On the facepack **Diagnostics** screen, verify that the primary controller has been "Assigned" and is "Communicating."

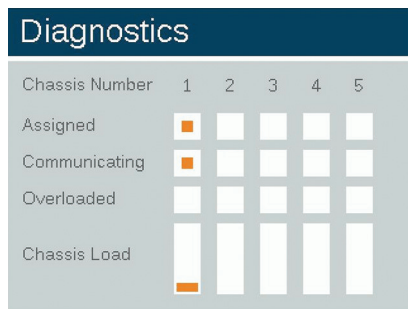

Figure 31: Diagnostics screenshot

3. Apply power to satellite controllers.
4. On facepack **Diagnostics** screen, verify satellite controllers have been "Assigned" and are "Communicating."

Before proceeding, confirm that the number of total chassis assigned and communicating equal the total number of primary and satellite controllers.



### Note

The assigned chassis numbers do not always correspond with the installed primary and satellite controllers shown on the display.

## Wireless Communication and Assignment

Before programming, determine which Wireless Linking Module (LINK-MOD in North America or LINK-MOD-E outside North America) will be installed on the primary ZDClk Controller.

For more information on Wireless ZDClk Linking setup, use the link below.

**Regular Preventive Maintenance**

Perform the following regular preventive maintenance procedures:

CATEGORY	DESCRIPTION	TIMELINE
<b>Transformer</b>	Tighten all terminal lugs.	Annually
	Blow out all bugs and webs.	Annually
<b>Luminaires</b>	Clean dirty lenses to minimize calcium deposits.	Annually
	Straighten all pathway lights.	Quarterly
	Trim all plant material as needed; relocate luminaires as needed as plant materials mature.	Quarterly
	Clean debris off well light lenses and grates.	Quarterly
	Check cable and cable connectors.	Annually
	Rebury cable and connectors that may have crept to the surface.	Semiannually
	Check aiming angles.	Semiannually
	Check, adjust, and replace all cable and cable ties in trees.	As needed



**Note**

When replacing luminaire LED boards, be sure to use Lumascape LED boards. Use of other brands may cause the luminaire to malfunction.

## Troubleshooting

PROBLEM	CAUSE	RESOLUTION
Error message: “Overload” (uppercase “O”)	An uppercase “O” overload indicates current far in excess of normal operating current, typically caused by a short circuit. This is controlled by a hardware circuit and trips the overload immediately.	Check for shorts in the line. Resolve or repair the short circuit.
Error message: “overload” (lowercase “o”)	A lowercase “o” overload indicates a current in excess of the rated current, but not as much as the uppercase “O.” For 150 W transformers the limit is 11 A, and for 300 W transformers the limit is 22 A. For this current to trip the overload, it must be continually above these values for one second.	Reduce the number of luminaires by one, turning on, and repeating until the “overload” does not occur. Resolve/repair the short circuit.
Error message: “No Wi-Fi Card Present”	Wi-Fi card not detected.	Pull out the Wi-Fi Card and re-insert. If problem persists, replace with a new Wi-Fi card.
Error message: “Communications Failure”	Communication between the facepack and chassis is not present.	Replace the cable connecting the facepack to the chassis. If problem persists, call Lumascape Technical Services.
Transformer will not turn off when program is complete.	No off time programmed.	Go to programs and add an event time with an intensity of zero for your off time.
The transformer display is on, but no luminaires are on.	The transformer’s fuse has blown.	Replace the fuse in the transformer.



### Note

Shorts and overloads are not covered by the Lumascape warranty and can be detected only when the transformer is tested in the field. Periodic system maintenance is required to keep your Lumascape lighting system operating at peak performance. Practicing these maintenance suggestions will lengthen the life and enjoyment of your lighting design.

## Firmware Updates

Firmware updates are occasionally released to add features or enhance the ZDClink functionality. To update the facepack, chassis, Wi-Fi module, and flash firmware on the ZDClink Controller, an SD card is required to transfer the data from a computer to the facepack.

1. Go to the Lumascape website ([lumascape.com](http://lumascape.com)) and navigate to the ZDClink product page. The firmware update files are located under the **Downloads** tab.
2. Save the desired firmware onto an SD card.
3. Remove the facepack from the chassis by pulling on the tab to the right of the facepack and swinging the facepack door open.
4. Pull the black tab outward while pushing the facepack through the door carriage.
5. Insert the SD card with the pins facing the front of the facepack, pressing completely inward. Then release to lock the card into place.
6. From the **Home** screen, select **Setup**. Navigate to the **Firmware** tab and press the scroll wheel.

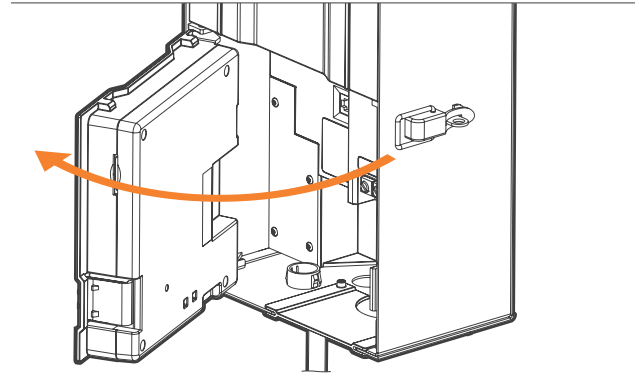

Figure 32: Facepack open

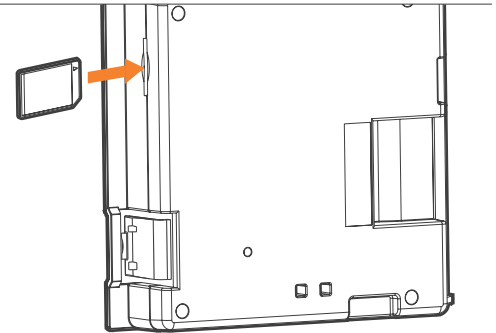

Figure 33: SD card installation

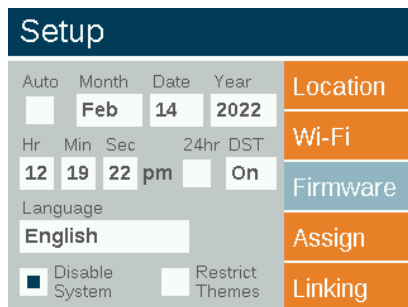

Figure 34: Setup screen (firmware)

7. Select the **Firmware Type** that will be updated.
8. Once the designed type is selected, navigate to **Update** and press the scroll wheel. The facepack and flash update processes usually take between 5 and 15 seconds, chassis updates typically take a couple of minutes, and luminaire updates can take up to 15 minutes.

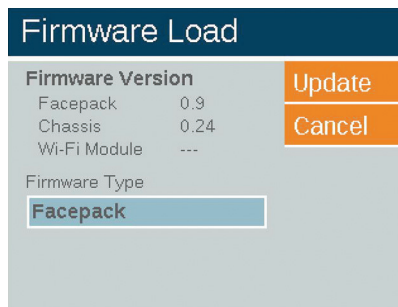

Figure 35: Firmware load screenshot



## Fuse Replacement

If the unit is powering on, but the luminaires attached are not receiving power, the fuse may need to be replaced. To replace the fuse, follow the directions below:

1. Unplug the ZDClk Controller from power.
2. Remove all wires from the Common and 15 V terminals on the chassis.
3. Remove the four screws from the fuse cover.
4. Remove and replace the fuse with the following specifications:
  - $\frac{3}{16}$ " x  $\frac{3}{4}$ " (5 mm x 20 mm)
  - 25 V
  - 10 A
  - UL rated
5. Replace the cover and four screws, reattach the luminaire wires, and restore power to the controller.

## System Reset

There are two types of system resets: facepack reset and database reset. The facepack reset simply removes power to the facepack and restarts the firmware. A database reset deletes the entire database to allow the user to start from scratch. All program data is lost during a database reset, but luminaire assignments remain intact.

### Facepack Reset

1. Remove the facepack from the chassis by pulling on the tab to the right of the facepack.
2. Swing the facepack door open.
3. Locate a paper clip, pen tip, or other small-point tool.
4. Locate the reset button on the back of the facepack.
5. Press and hold the reset button for two seconds using the selected tool.

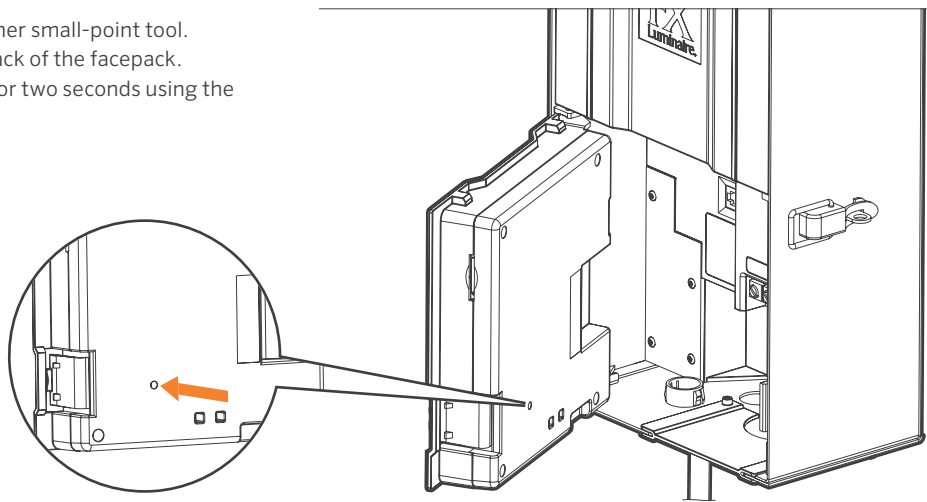

Figure 36: Reset button

### Database Reset

1. From the **Home** screen, push the **Home** button and the **Back** button simultaneously to bring up the **Diagnostics** screen (Figure 2 on page 3).
2. Wait two seconds and press the center scroll wheel.
3. Navigate to the **Clear** option and press the scroll wheel (Figure 37).

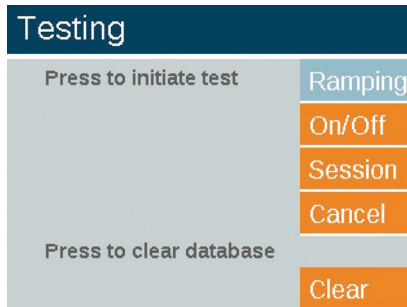

Figure 37: Engineering testing screenshot



**Note**

Clearing the database does not erase luminaire group assignments (page 17).

### Chassis Indicator Lights

An indicator light displays the communication status of the chassis to the facepack. The following colors indicate the accompanying status:

- **Blinking green:** Communication established
- **Amber:** Communication error/facepack unplugged
- **Red:** Short or overload detected in the system

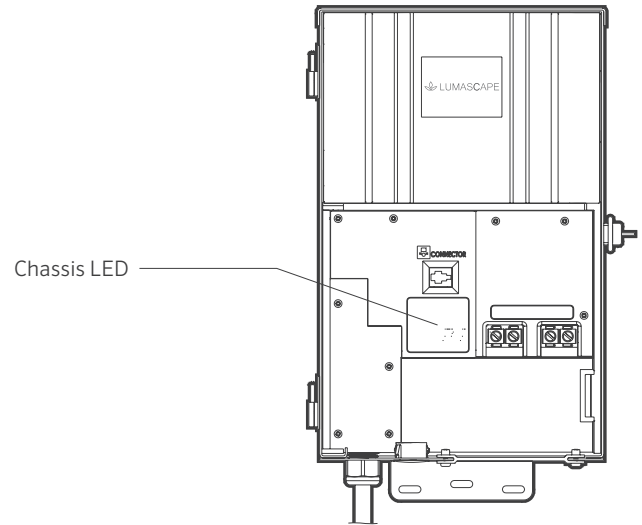

Figure 38: Chassis indicator lights

## Statement of Limited Warranty

Hunter Industries Incorporated (“Hunter”) warrants Lumascope lighting products to be free of defects in materials or workmanship under normal use for a period of five (5) years from the date of invoice.

If a defect in a Lumascope product is discovered during the applicable warranty period, Hunter will repair or replace, at its option, the product or the defective part. This limited warranty does not extend to repairs, adjustments, or replacement of Lumascope products or parts resulting from misuse, negligence, alteration, modification, tampering, or improper installation and/or maintenance of the product. This warranty extends only to the original installer of the product. If a defect arises in a Lumascope product or part during the warranty period, contact the local authorized manufacturer’s representative.

Hunter’s obligation to repair or replace its products as set forth above is the sole and exclusive warranty set forth by Hunter. There are no other warranties, expressed or implied, including warranties of merchantability and fitness for a particular purpose. Hunter will not be liable to distributor or any other party in strict liability, tort, contract, or any other manner for damages caused or claimed to be caused as a result of any design or defect in Lumascope products, or for any special, incidental, consequential, or exemplary damages or any nature, including without limitation lost business or profits.

Notwithstanding the foregoing, if for any reason Hunter is found to be liable, in no event shall Hunter’s liability exceed the price of the product which gives rise to the claim, loss, or damage.

If you have any questions concerning the warranty or its application, please write to:

Lumascope Customer Service Department  
1940 Diamond Street  
San Marcos, CA 92078 USA

## Regulatory and Legal Information

This equipment has been tested and found to comply with the limits for a Class B digital device, pursuant to part 15 of the FCC Rules. These limits are designed to provide reasonable protection against harmful interference in a residential installation. This equipment generates, uses and can radiate radio frequency energy, and if not installed and used in accordance with the instructions, may cause harmful interference to radio communications. However, there is no guarantee that interference will not occur in a particular installation. If this equipment does cause harmful interference to radio or television reception, which can be determined by turning the equipment off and on, the user is encouraged to try to correct the interference by one or more of the following measures:

- Reorient or relocate the receiving antenna.
- Increase the separation between the equipment and receiver.
- Connect the equipment into an outlet on a circuit different from that to which the receiver is connected.
- Consult the dealer or an experienced radio/TV technician for help.

The user is cautioned that changes/modifications not approved by the responsible party could void the user's authority to operate the equipment.

To satisfy FCC RF Exposure requirements for mobile and base station transmission devices, a separation distance of 20 cm or more should be maintained between the antenna of this device and persons during operation. To ensure compliance, operation at a closer distance is not recommended. The antenna(s) used for this transmitter must not be co-located or operating in conjunction with any other antenna or transmitter.

This device contains licence-exempt transmitter(s)/ receiver(s) that comply with Innovation, Science and Economic Development Canada's licence-exempt RSS(s). Operation is subject to the following two conditions:

1. This device may not cause interference.
2. This device must accept any interference, including interference that may cause undesired operation of the device.

L'émetteur/récepteur exempt de licence contenu dans le présent appareil est conforme aux CNR d'Innovation, Sciences et Développement économique Canada applicables aux appareils radio exempts de licence. L'exploitation est autorisée aux deux conditions suivantes :

1. L'appareil ne doit pas produire de brouillage;
2. L'appareil doit accepter tout brouillage radioélectrique subi, même si le brouillage est susceptible d'en compromettre le fonctionnement.







Our mission is to create the most energy-efficient lighting products in the world while maintaining the highest level of quality and reliability. In every instance we will back our innovations with the unwavering support our customers need to succeed.

A handwritten signature in black ink that reads "Gene Smith". The signature is fluid and cursive, with a long horizontal stroke extending to the right.

**Gene Smith, President, Landscape Irrigation and Outdoor Lighting**

**Lumascape** | Architectural & Facade Lighting  
1940 Diamond Street, San Marcos, CA 92078 USA  
lumascape.com



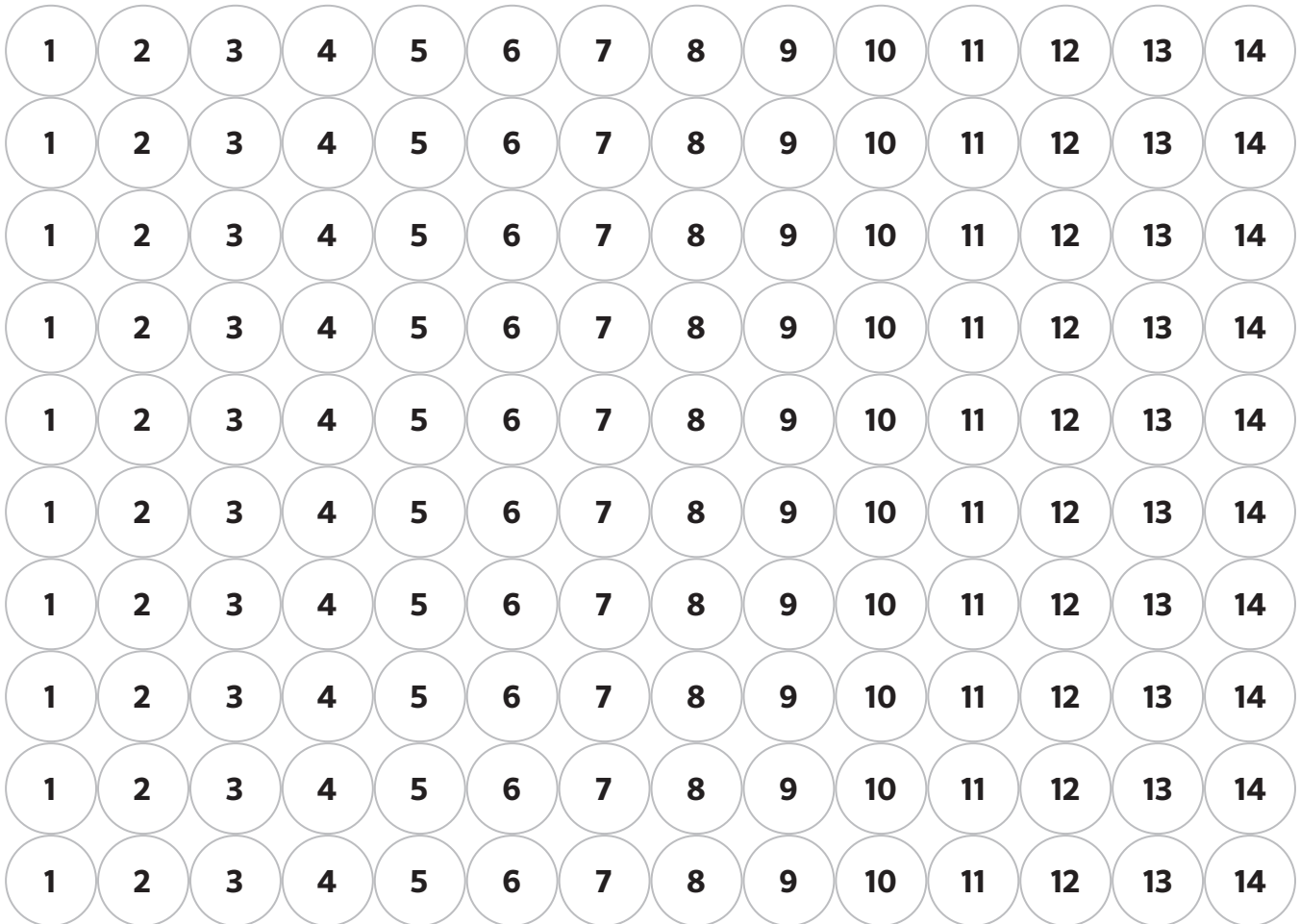

To simplify installation, use these stickers when programming luminaires at the ZDCLink Controller facepack or with the Light Assignment Module. Place the stickers on luminaire wires to create a visual reference for group numbering in the field.

# Luminaire Group Stickers

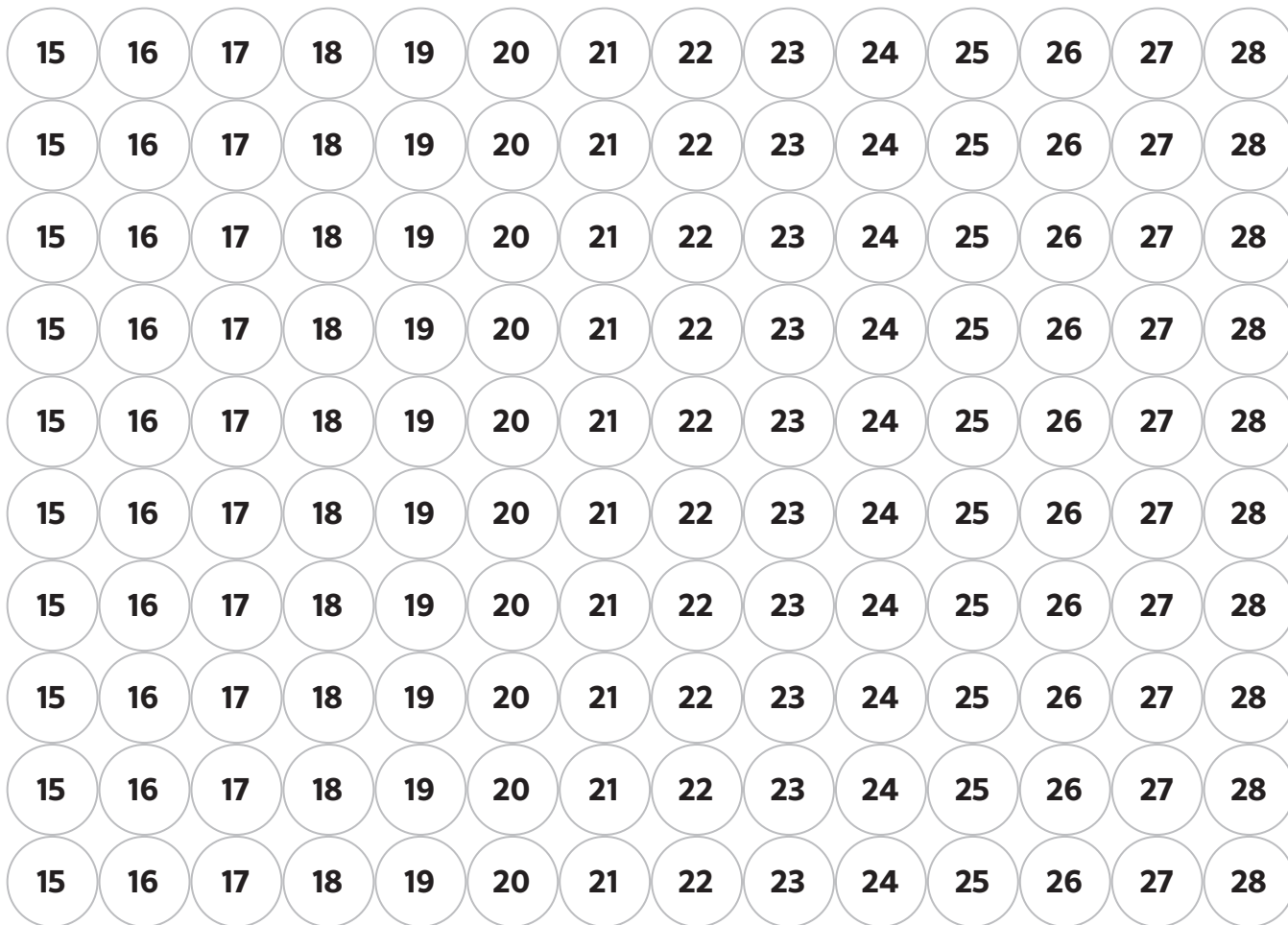

To simplify installation, use these stickers when programming luminaires at the ZDCLink Controller facepack or with the Light Assignment Module. Place the stickers on luminaire wires to create a visual reference for group numbering in the field.